

## CLEANING OF ARCHITECTURAL BRICKS USING RF PLASMA. I. METALLIC STAINS

Mohamed El-GOHARY<sup>1\*</sup>, Asem METAWA<sup>2</sup>,

<sup>1</sup> Department of Conservation, Sohag University, 82524 Sohag, Egypt

<sup>2</sup> Department of Physics, Al-Azhar University, 11488 Cairo, Egypt

### Abstract

*RF Plasma is a glow discharge typically generated through using oxygen and hydrogen as the input working gas. In the current study the radio frequency (RF) hydrogen plasma (H<sub>2</sub>) is used for removing some metallic stains (iron and copper) which affected the historical brick surfaces in Prince Yousef Kamal place. Untreated and treated surfaces were evaluated by OLS, EDX-SEM & FTIR. Investigation results show that both iron and copper aged samples had been cleaned, where the stains thicknesses' were removed perfectly through. Analytical results of the accumulated particles demonstrate that they are decreased after cleaning process. In addition, morphological investigations proved the clearness of positive effects in the reducing of the samples surfaces' darkening and thickness' accumulations in all cleaned samples.*

**Keywords:** Dielectric barrier discharge; Capacitive coupled plasma; Artificial ageing; SEM-EDX, FTIR

### Introduction

The *Radio Frequency (RF)* capacitive gas discharge is widely used in various technological surface processes such as thin film deposition, plasma etching and surface cleaning [1-5]. Plasma cleaning involves the removal of impurities and contaminants from surfaces through using different types of energetic plasma such as RF plasma, DC glow discharge and *Dielectric Barrier Discharge (DBD)*. It was created from gaseous species (ions, excited atoms, electrons and positive ions), as well as other mixtures (air and hydrogen/nitrogen) [6]. *Plasma cleaning*, that can be produced by active gas oxygen, hydrogen or argon usually refers to the removal of some contamination layers from the material surface due to the reaction between the discharged components (i.e., ion, electrons excited atoms) with the impurities at the surface [7, 8]. In the current study *RF plasma* has been formulated to clean some brick surfaces collected from *Prince Yousef Kamal Palace in Nag Hammadi* (Fig. 1). It has suffered from severe contamination symptoms created by different organic and inorganic effects. Among these symptoms, there are some stains and rested spots created by iron and copper as inorganic sources, as well as soot as an organic source.

Cleaning of monumental buildings is an essential operation that has a wide range of techniques ranging from large facades to some small findings [9-12]. Moreover, it ranges from regular dusting and damp-mopping of objects to removing dirt, accumulations or stains [13]. Though care must be taken to retain dirt that is part of the history of an object, such as soot on

\* Corresponding author: m\_1968\_algoahary@yahoo.com

an ancient cooking spot [14, 15]. This process, which is a positive action, means protection against harmful materials accumulated on the surface such as crusts, weathering products or different salt crystals [16]. It prevents adverse reactions between the object and its environment [17]. It is often one of the first steps to be undertaken for removing all accumulated dirt to enhance the better seen of the underlying stone conditions, thus judging what further conservation may be necessary [18, 19]. However, it is one of the most difficult operations in building conservation and restoration [9, 20]. In this regard, the ideal cleaning should lead to the removal of as much of the fouling and as little of the material as possible by a combination of physical and chemical techniques [21].



**Fig. 1.** Prince Yousef Kamal place in *Nag Hammadi*

According to I. Bristow [9, 22-25] these techniques may have negative effects if they are done without sufficient investigations. They vary from mechanical, abrasive, chemical (wet & dry), poultices, enzymes, laser and plasma cleaning techniques. RF plasmas are more efficient in converting the power from the supply into the plasma and more importantly in etching [26-30]. RF plasmas are a glow discharge typically generated by an RF source. RF discharge may be divided into two types according to the form of electromagnetic field interaction; *Inductively Coupled Plasma (ICP)* or *Electrode Less Discharge (ELD)* and *Capacitive Coupled Plasma (CCP)*. It is a discharge that has been produced between two parallel plates (electrodes), where, the area of the two electrodes and the gap space between them affected the discharge condition. Also, it is widely used in various technological processes such as thin films deposition, treatment and surface cleaning [29, 30]. In the current study, *CCP* has been used to clean some historical brick surfaces through using two regions within the discharge. They are *\*sheath region* at the electrodes and *\*bulk region* at the center [31-33]. The ions accelerated within sheath region play the important role in the cleaning and modification processes on the solid material surfaces through using active species produced by plasma treatment. This mechanism that may be achieved by adding or removing adsorbed monolayers involves chemical reactions with the surface; adds or removes surface charge; changes physical or chemical state of the superficial monolayers of a material [34]. According to some specialists [35-39] the main principle of the plasma cleaning is that the ionized excited molecules and radicals, created by the electrical field, bombards and reacts with the surface of the sample. These activated molecules may etch, sputter, some layer from the substrate surface. These mechanisms lead to changes to the surface properties of substrates. When introducing molecular gases into plasma, chemically, active species are formed, such as molecules in excited states, radicals and ions. Layer corrosion is removed from the substrate through seven steps [40]. These steps are: **a)** Formation of the reactive particle, **b)** Arrival of the reactive particle at the surface to be etched, **c)** Adsorption of this particle at the surface, **d)** Forming chemical reaction "the reactive particle"

at the surface, i.e. a chemical bond is formed, e) Formation of the product molecule, f) Adsorption of the product molecule, g) Removal of the product molecule from the reactor.

The surface may be cleaned by plasma etching if a volatile chemical compound is formed by the bombardment [41]. These species can react with each other, neutral molecules or with the surface of the sample. Within the same context, it could be claimed that the reaction of the plasma has two forms: reduction and oxidation reactions based on the nature of the molecules and the process conditions. On one hand, plasma reduction or hydrogen plasma allows the reaction of chlorinated products, oxides as well as corrosion products from the historical bricks through a reduction process based on the presence of atomic hydrogen [42].

## Experimental

The experimental apparatus used in this study is a capacitively coupled parallel plate reactor with an asymmetric electrodes configuration. It consists of a stainless steel vacuum chamber and a powered electrode connected to an RF power supply (10MHz). Some residual brick units were collected from Prince Yousef Kamal Palace (built in *Nag Hammadi* 1925) on the west bank of the Nile. They were investigated and analyzed to estimate the quantitative and qualitative proportions of their surface's accumulations using some scientific techniques. These processes were achieved by EDX attached to SEM & DBM. Furthermore, some cubes samples' (4×4×1cm.) of historical bricks were laboratory prepared from the original blocks to be a target for experimental tests.

### *Stains simulation (Artificial ageing)*

The brick samples collected from the site under the study were prepared in a square shape (4×4×1 cm.). They were submitted to the aging processes by using some metallic rusting stains. These stains lead to creating some artificial deposits or stains matched with the original ones. These accumulated stains were divided into two types according to the following criteria:

- Iron corrosion layers; they were laboratory prepared by putting some fragments of corroded iron on the samples of brick surface and spraying some water drizzle, then heating in 70-80°C. This step results in forming an orange color on the samples surfaces. This demonstrates that rusting of iron and creating of manifested stains was composed of ferric oxides according to the following formulas. These oxides are mostly *goethite*, *limonite* or *hematite* through a complex electrochemical process that begins with the transfer of electrons from iron to oxygen [43].

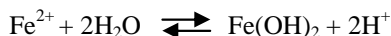

As do the following dehydration equilibria:



- When light is being shed on the *copper stains* sample; through the preparing of a simulation study (different stains on the surface of brick) the copper stain has been prepared by mixing the sulfuric acid with the copper sheets on the brick surfaces according to the following formulas. Then, copper sulfates are composed, which is called *brochantite*  $\text{Cu}_4\text{SO}_4(\text{OH})_6$ , and much rarely *antlerite*  $\text{Cu}_3\text{SO}_4(\text{OH})_4$  [44], see following formulas:



### Cleaning procedures

The contaminated samples have been put between two electrodes in the plasma chamber that can be evacuated down to 50 mtorr (Fig. 2). Then the gas has interred the cell with 70-mtorr pressure, the discharge can be generated with different timing. The cleaning time varies from 1 to 3 hours; the RF power works for 15 min. every time.

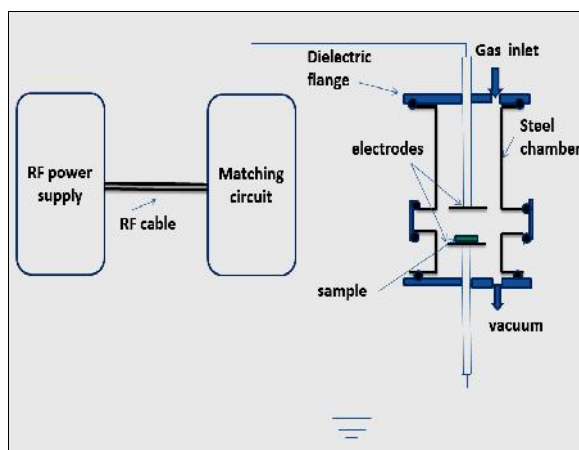

Fig. 2. Schematic diagram of the CCP cleaning experiment arrangement

### Evaluation processes

In the conservation field, different techniques based on different scientific referential have been used for evaluating the quantitative and qualitative dirties accumulated on the archaeological surfaces. Some of these techniques are based on physical methods [45-47] and others are based on chemical ones [48-50]. In the current study, *Bausch & Lomb* attached to computerized *Jenalux 20 stereo-microscope* has been used to investigate the external features of the sample surfaces.. As well as *JSM 5300* scanning electron microscope coupled with energy dispersive x-ray spectroscopy (*SEM-EDX*) had been used for assessing chemical proportions and surface morphology of the samples before and after cleaning processes. *FTIR* is one of the widest and useful applications used in the diagnosis of the historical object and treated surface after cleaning [51]. These applications include the identification of molecular compounds created at the artwork surface, studies of the composition of painting layers and investigations of epoxy resins [52]. According to some specialists [53-54], *FTIR* investigations have been carried out with *Alpha Bruker Optics Middle*, and *Fourier transformation* in 3500 to 400  $\text{cm}^{-1}$  frequency region. They are used to study the vibrational bands that provide information about the chemical functional groups of collected powder samples (before & after the cleaning process by RF Plasma).

## Results

### OLS investigations results

The stereomicroscope captures of aged and cleaned samples were completely different due to ageing processes. On one hand, the aged samples are characterized by the presence of some severe inorganic stains on the brick surfaces simulated with those present on walls. The colors of these samples surfaces are **orange** in the state of iron corrosion layers (A), and **blue** with heavy particles of copper chloride (B). In addition, there is an increase of brightness and roughness of iron corroded samples; all of these features are shown in figure 3a. On the other hand, the results of cleaned samples show that both the iron aged samples (A) and copper-aged

samples (B) had been cleaned where the stains thickness were removed perfectly through treating by hydrogen ( $H_2$ ) plasma, figure 3b.

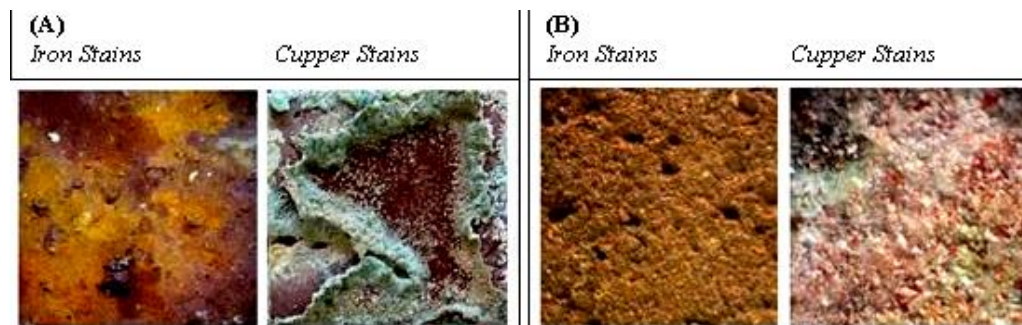

Fig. 3. OLS photos of brick samples **a.** iron corrosion layers & copper stains before cleaning, **b.** the same samples after plasma cleaning

#### ***EDX coupled with SEM results***

EDX analytical results of the particles accumulated on brick surfaces demonstrate that they vary according to the stain types. On the other hand, the same analytical results after plasma cleaning attest that there are some differences between up and down in samples (A) and (B). These results are listed in table 1. SEM obtained results prove that there are heavy, entangled, dense and harsh layers of iron rust (A) and copper stains (B) accumulated on the brick surfaces, figure 4a. SEM-EDX investigations that were used to check the efficiency of cleaning processes proved the next points:

- a. the clearness of positive effects in the reducing of darkening of samples surfaces;
- b. the reduction of stain and accumulations thickness in all cleaned samples (A) and (B);
- c. the increase of the samples porosity both in samples (A) and (B), in addition to the observation of clear porosity indexes and brightness and micro damaging in some zones of brick surfaces, compared to the same samples before cleaning (Fig. 4b).

#### ***FTIR results***

The FTIR spectrum analysis results of **iron corrosion layers** before and after cleaning by RF plasma prove that both quartz and hematite are the main minerals occurring in different concentrations in the samples surface layers. The absorption bands in the region ( $800-1200\text{cm}^{-1}$ ) are attributed to Si–O stretching vibrations, and the region ( $700-1000\text{cm}^{-1}$ ) is attributed to the hydrated iron oxides  $\text{FeO}(\text{OH})$ . In addition, there is a presence of iron oxides in the region ( $400-700\text{cm}^{-1}$ ), and a presence of  $\text{AlO}_6$  at the vibrational bands ( $575\text{cm}^{-1}$ ) and  $\text{Al}(\text{OH})_3$  at ( $691\text{cm}^{-1}$ ), both before and after cleaning processes. On the other hand, it could be noticed that there are some differences (both qualitatively and quantitatively) in FTIR results due to the effect of RF plasma (table 2). Regarding the investigation results of **copper stains** by FTIR, it could be noted that there are 11 vibrational bands before the cleaning process and 13 bands after. Sulphur (S–O) group are registered 11 times; 6 before plasma cleaning at the vibrational bands ( $451-781\text{cm}^{-1}$ ), then they are decreased to 5 after the cleaning process ( $542-793\text{cm}^{-1}$ ). On the other hand, the silicate (Si–O) group are present at 2 vibrational bands ( $791$  and  $1067\text{cm}^{-1}$ ) before cleaning that were increased after cleaning to 6 bands, which made their appearance at the regions between ( $459, 777, 1067, 1436, 2053$  and  $2977\text{cm}^{-1}$ ). Finally, it

could be noted that hydroxyl (OH) group is registered 3 times before cleaning at (1648, 1665, 3097cm<sup>-1</sup>) vibrational bands and decreased into 2 vibrational bands after cleaning (1632 and 1659cm<sup>-1</sup>) (table 3).

**Table 1.** Percentages of stain types before and after cleaning processes

Stain Types	Elemental Ratios								
	C	Al	Si	S	Cl	Ca	Fe	Cu	Total
<b>Before cleaning</b>									
Iron (A)	79.10	3.00	7.40	-	0.277	1.85	8.37	-	99.997
Copper (B)	-	6.52	2.23	20.14	2.16	1.04	-	67.91	100.00
<b>After cleaning</b>									
Iron (A)	37.4	32.4	18.6	-	2.85	2.5	6.254	-	100.00
Copper (B)	-	8.11	4.77	19.99	4.96	4.27	-	57.9	100.00

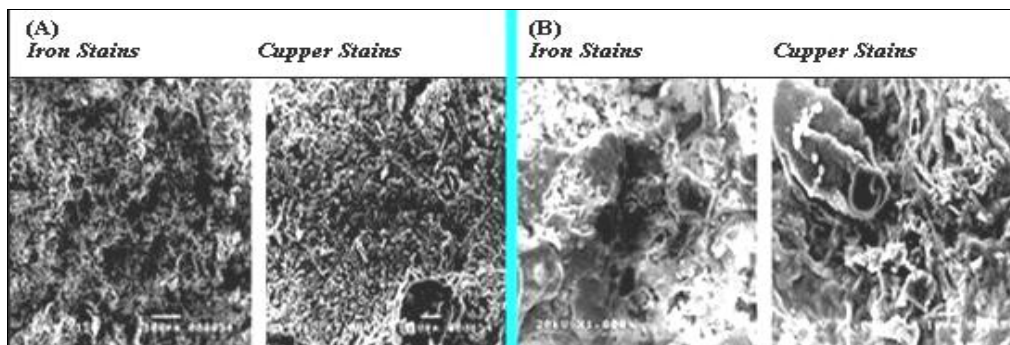

Fig. (4) SEM photomicrographs of brick samples **a** iron corrosion layers & copper stains before cleaning, **b** the same samples after plasma cleaning

**Table 2.** FTIR analytical results of iron corrosion layers before and after cleaning

Compounds	Peaks Identifications Bands (cm <sup>-1</sup> )		
	Before Cleaning	Compounds	After Cleaning
Si-O / FeO	461	FeO	430
FeO	536	Si-O / FeO	461
AlO <sub>6</sub> / FeO	575	FeO	534
FeO	630	AlO <sub>6</sub> / FeO	575
FeO	675	FeO	626
Al(OH) <sub>3</sub> / FeO	691	FeO	677
Si-O	734	Al(OH) <sub>3</sub> / FeO	691
Si-O	777	Si-O	732
Si-O	793	Si-O	777
Si-O	1010	O-H	940
Si-O	1036	Si-O	1004
Si-O / FeO	1053	Si-O / FeO	1020
Si-O	1075	Si-O / FeO	1053
		Si-O	1079

**Table 3.** FTIR analytical results of copper stains before and after cleaning

Compounds	Peaks Identifications Bands (cm <sup>-1</sup> )		Compounds	After Cleaning
	Before Cleaning			
S-O	451		Si-O	459
S-O	542		S-O	542
S-O	593		S-O	591
S-O	610		S-O	612
S-O	675		S-O	673
S-O	781		Si-O	777
Si-O	791		S-O	793
Si-O	1067		Si-O	1067
OH	1648		Si-O	1436
OH	1665		OH	1632
OH	3097		OH	1659
			Si-O	2053
			Si-O	2977

## Discussion

Through explaining the previous data, it could be said that the dirt and dust accumulated on the archaeological surfaces gathered over the years both represent a threat and great problem during the conservation of these surfaces [55]. Furthermore, these accumulations are not only capable of retaining moisture on the buildings' surfaces, which in turn help in the growth of fungal spores, but also attract the fungal spores in question [56]. From an aesthetical perspective, this problem has increased in urban areas [57, 58] where the impact of the dirt makes the cleaning a relevant task within the conservation activities, and also very expensive, due to the frequency that would be required [20]. Therefore, the cleaning of archaeological surfaces requires multidisciplinary approaches, in order to develop new strategies for the conservation and protection of their units from the severe effects of accumulations. These strategies should be matched with an international code of ethics and practices [59-63]. Moreover, these strategies should be achieved through enhancing new techniques, such as low-pressure plasmas (*cold plasma*). It is considered one of the new techniques used in the archaeological field due to its major aforementioned advantages. Within the same context, the effectiveness of cleaning should be advisably evaluated from the variation of several parameters. These parameters include surface colors by *OLS*, quantities of stains accumulations by *EDX* and the minor damages existent on the cleaned surfaces by *SEM*.

The results of the RF plasma cleaning, (Figure 3-b) prove that there are noticeable changes in the samples' external surfaces (A), iron-aged samples and (B) copper-aged samples. These changes are mainly due to two factors: the suing of H<sub>2</sub> plasma in the cleaning processes of (A) and (B) samples, and also the decreasing of accumulated impurities, both in their depth profiling and in their concentration. In addition, *OLS* photos attest that sample (A) is completely cleaned and sample (B) is only partially cleaned. Moreover, the distortion on surface (B) is decreased and is smoother when compared to the sample before treatment. On the other hand, the removal of chlorine (B) depends on the sample temperature, whereas the subsequent data proves that chlorine removal is better carried out in hydrogen-containing plasma than in other types of plasmas, as previously attested [64-66].

The analytical results of *EDX* (Table 1) demonstrate that the components of these accumulations decrease and vary according to the stain types. In the case of iron-aged samples (A), the percentages of (Fe) indicate that its concentration was decreased by (25.28 %) after plasma treatment. Regarding sample (B), the percentage of Cu was



decreased accurately and became (14.75 %) after plasma treatment. Additionally, it may be noted that there is a noticeable increase concerning the main components of the brick surface that contain (Al, Si and Ca) in all sample types. This increase (437%) is recorded in sample (A) and also (179 %) in sample (B). From this perspective, it may be argued that the results prove that RF hydrogen plasma is extremely useful, in terms of maintaining optimum cleanliness after the samples' preparation. In addition, it is a useful technique for the cleaning of the corrosion products and elimination of chlorides responsible for deterioration, due to its significant ability to reduce the thickness of the corrosion layers [64, 65, 67-69].

In *SEM*, imaging was performed in order to evaluate the changes in the surface's morphology and the efficiency of the samples' morphology induced by plasma treatment. Through evaluating heavy, entangled, dense and harsh layers of iron rust (A) and copper stains (B) observed by SEM in untreated brick samples Figure 4a, it could be said that these accumulations are essentially owed to the effects of aging processes mentioned in the experimental section. Furthermore, the changes in surface morphology show significant differences after cleaning processes by plasma reduction, where, a clear separation of the outer corrosion layers from the original surface was observed [70, 71]. The changes in surface morphology were noted in Figure 4b after cleaning processes; the basic structure of the brick surface appeared and the dirty layer was etched by plasma. Regarding micro damaging in some zones of brick surfaces, it could be claimed that these symptoms resulted essentially from the effects of plasma processing on silicon lattice as a main component of the brick structure [72-73].

Through explaining FTIR spectrum analyses before cleaning (Table 2), it could be observed that peaks at (461, 734, 777, 793, 1010, 1036, 1053 and 1075 $\text{cm}^{-1}$ ) correspond to the stretching vibration of Si-O. This indicates that those peaks deal with the presence of silicates either in its amorphous or crystalline phases (one of the brick components such as quartz and kaolin) [74, 75]. Furthermore, it could be noted that iron oxides are observed in the spectral region of 400-700  $\text{cm}^{-1}$ , as previously attested by *Sathya, et al* [76]. In those cases where the obtained peaks at (461, 536, 575, 630, 675, 691 and 1053 $\text{cm}^{-1}$ ) correspond to the vibrational bands of iron, peak (536 $\text{cm}^{-1}$ ) in particular indicates the presence of Ferric oxide [77]. The presence of magnetite and hematite provides interesting information about the weathering products [78], and could also offer further information regarding the provenance of the clay used for the mixture [79]. Finally, the presence of  $\text{AlO}_6$  at the vibrational bands (575 $\text{cm}^{-1}$ ) and  $\text{Al}(\text{OH})_3$  at (691 $\text{cm}^{-1}$ ) indicate the presence of (aluminum oxide) and (bayerite), which are considered two of the essentials of brick components [80]. Regarding the FTIR data of the same samples after cleaning, it could be noted that the peaks' transmittance increases and the position of the peaks has been shifted towards the upper wave number. Moreover, the gradual concentration decrease has been observed in cleaning processes by RF plasma, where there are some bands of Si-O are contained (461, 575, 777 and 1053 $\text{cm}^{-1}$ ). In addition, the appearance of another 5 peaks at (732, 1004, 1020 and 1079 $\text{cm}^{-1}$ ), after cleaning could be owed to the effects of plasma cleaning procedures [81]. Within the same context, it could be noticed that the vibrational bands of FeO appear 7 times (461, 536, 575, 630, 675, 691 and 1053 $\text{cm}^{-1}$ ) before cleaning and then increase after cleaning (430, 461 534, 626, 677, 575, 691, 1020 and 1053 $\text{cm}^{-1}$ ). This may be due to the occurring of  $\alpha$ -FeOOH (goethite) at (461 $\text{cm}^{-1}$ ) and  $\gamma$ -FeOOH (Lepidocrocite) at (1020 $\text{cm}^{-1}$ ) [82, 83]. In addition, O-H deformation vibrational mode is separated into (940 $\text{cm}^{-1}$ ) [84]. The FTIR spectrum analyses the results of copper stains before and after cleaning showed in Table 3.

It is therefore proven that the copper sulfates before the cleaning process are present in three forms; Brochantite  $\text{Cu}_4\text{SO}_4(\text{OH})_6$ , Antlerite  $\text{Cu}_3\text{SO}_4(\text{OH})_4$ , and Posnjakite  $\text{Cu}_4\text{SO}_4(\text{OH})_6 \cdot 6\text{H}_2\text{O}$ . This is proved by displaying the characteristic stretching bands of S-O



vibration in  $\text{SO}_4$  groups at the region between ( $400\text{--}800\text{cm}^{-1}$ ) [74]. Where, it appears at medium bands ( $451, 593, 610\text{ cm}^{-1}$ ) and weak bands ( $542, 675, \text{ and } 781\text{cm}^{-1}$ ) [85]. On the other hand, Si–O group registered at the absorption of the strong band ( $1067\text{ cm}^{-1}$ ) and weak band ( $791\text{cm}^{-1}$ ). Within the same context, stretching bands of O–H groups are located at the region ( $1648\text{--}3097\text{cm}^{-1}$ ) [44], where, it was recorded at a broad band ( $3097\text{cm}^{-1}$ ) and narrow bands at ( $1648 \& 1665\text{ cm}^{-1}$ ). After the cleaning process, all FTIR bands shift beyond ( $542 \text{ and } 1067\text{cm}^{-1}$ ) and the quantity of bands increases up to 13 instead of 11 bands before cleaning. The bands attributed to brick components (Si–O) increase from 2 to 6 bands at the regions ( $459, 777, 1067, 1436, 2053 \text{ and } 2977\text{cm}^{-1}$ ) as noted before by many scientists [76, 86, 87]. While the numbers of the bands attributed to copper sulfate (S–O) are decreasing from 6 into 5 bands, the bands attributed to hydroxyls groups are decreasing after cleaning to 2 instead of 3 before cleaning. Furthermore, through explaining the deconvolution diagram of FTIR of brick surface contaminated by the copper stain; it could be said that there is an increase in the height of some peaks after cleaning. This increase, which is essentially due to the increase of these peaks' transmittance, cause a decrease of both these peaks' width and their total area, as previously established by certain specialists in their case studies [88, 89]. These results are confirmed through the deconvolution of FTIR curves before and after plasma treatment (Figure 5a, b, c and d).

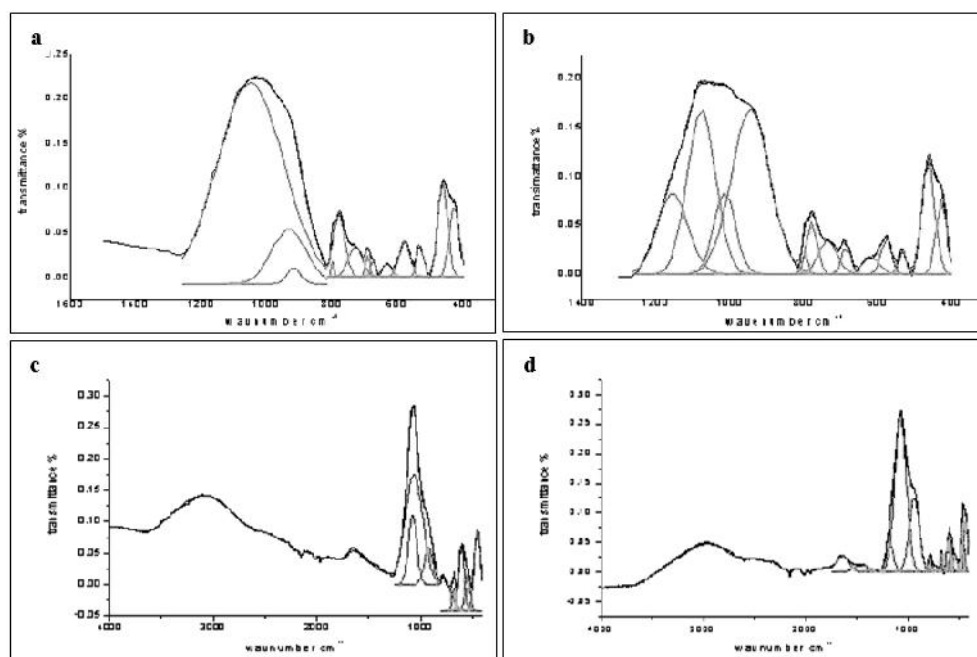

**Fig. 5.** FTIR spectrum of brick surface **a** with iron corrosion layers, **b** after plasma cleaning **c** with copper stains, **d** after plasma cleaning

## Conclusions

The main objective of this paper is to present the effectiveness of plasma as *NDT* in the cleaning processes of historic buildings. From our diagnostic studies that were performed on the architectural surfaces of Prince Yousef Kamal Place, it could be claimed that it was affected by different types of stains. Iron and copper represent the vast majority of these stains as inorganic matters. *RF* plasma was performed for cleaning many samples collected from the palace's surfaces; our assessment processes provide significant information after *RF* plasma treatment.

These information indicate that the (Fe) concentration was decreased about (25.28%) and (Cu) was decreased accurately and became (14.75%) after plasma treatment. In addition, increasing the main components of a brick surface that contain (Al, Si and Ca) recorded (437%) in sample contaminated by (Fe) and (179%) in the sample contaminated by (Cu). Therefore it can be concluded that RF plasma is an effective cleaning technique, particularly in the removal inorganic surfaces contaminants. To sum up, it could be claimed that RF plasma is an important cleaning technique used for the removal surfaces contaminants. In addition, other experiments should be carried out, using several different types of gases and contaminations, particularly of an organic nature. This target shall be achieved in the 2nd part of the research, which is entitled Cleaning of architectural bricks using RF plasma: "None Metallic Stains", in order to evaluate the validity of this technique as a pioneer and non-destructive cleaning technique for both inorganic and organic materials.

## References

- [1] A. Rastkar, A. Niknam, B. Shokri, *Characterization of copper oxide nanolayers deposited by direct current magnetron sputtering*, **Thin Solid Films**, **517**, 2009, pp. 5464-5467.
- [2] B. Segda, C. aperaa, M. Jacquet, *Characterization and dielectric properties of GeO<sub>x</sub> thin films prepared by radio frequency (RF) reactive sputtering*, **Nuclear Instruments and Methods in Physics Research B**, **266**, 2008, pp. 482-4836.
- [3] H. Miyazaki, T. Goto, *SiO<sub>x</sub> films prepared using RF magnetron sputtering with a SiO target*, **Journal of Non-Crystalline Solids**, **352**, 2006, pp. 329-333.
- [4] D. Das, A. Barua, *Properties of a-SiO:H films prepared by RF glow discharge*, **Solar Energy Materials. Solar Cells**, **60**, 2000, pp. 167-179.
- [5] Y. Sung, H. Kim, *Sputter deposition and surface treatment of TiO<sub>2</sub> films for dye-sensitized solar cells using reactive RF plasma*, **Thin Solid Films**, **515**, 2007, pp. 4996-4999.
- [6] M. Shun'ko, V. Belkin, *Cleaning properties of atomic oxygen excited to metastable state  $2s^2 2p^4 ({}^1S_0)$* , **Journal of Applied Physics**, **102**, 2007, pp. 083304-083314.
- [7] M. Mozeti, *Discharge cleaning with hydrogen plasma*, **Vacuum**, **61**, 2001, pp. 367- 371.
- [8] Z. Dai, S. Zhang, Y. Wang, *Study on feature profile evolution for chlorine etching of silicon in an RF biased Sheath*, **Vacuum**, **89**, 2013.197-202.
- [9] I. Bristow, *An introduction to the restoration, conservation and repair of stone*, **Conservation of Building and Decorative Stone**, Butterworth-Heinemann, London, 1990, p. 1.
- [10] J. Larson, *The conservation of stone sculpture in museums*, **Conservation of Building and Decorative Stone**, Butterworth-Heinemann, London, 1990, p. 197.
- [11] V. Fassina, S. Borsella, *The effects of past treatments on the acceleration of weathering processes in the statues on Prato delle Valle*, **Conservation of Stone and Other Materials**, RILEM, UNESCO, London, 1993, p. 129.
- [12] M. El-Gohary, *Experimental tests used for treatment of red weathering crusts in disintegrated granite - Egypt*. **Journal of Cultural Heritage**, **10**, (2009), pp. 471- 479.
- [13] D. Gilroy, I. Godfrey, **A Practical Guide to the Conservation and Care of Collections**, Perth, W.A., Western Australian Museum, 1998, p 88.
- [14] E. Pye, *Conservation and storage: archaeological material*, **Manual of Curatorship: A Guide to Museum Practice**, Butterworths, 1984, London, p. 392.
- [15] P. Kadlubowski, C. Bynum, *Façade cleaning: For more than appearance's sake*, *J. of architectural technology*, **19**(1), 2001, pp. 1-8
- [16] B. Feilden, **Conservation of Historic Buildings** (3<sup>rd</sup> edition), Routledge, London, 2003, p. 101.

- [17] D. Hamilton, *Methods of conserving archaeological material from underwater sites, Conservation of Archaeological Resources*, vol. I Nautical Archaeology Program, Department of Anthropology, Texas A&M University, 1999.
- [18] C. Price, **Stone Conservation: An Overview of Current Research**, The Getty Conservation Institute, USA, 1996, p. 29.
- [19] C. Grossi, P. Brimblecombe, *Effect of long-term changes in air pollution and climate on the decay and blackening of European stone buildings*, **Building Stone Decay: From Diagnosis to Conservation**, Geological Society Special Publication, London, 2007, p. 117.
- [20] A. Calia, L. Matera, M. Lettieri, *Compact limestones as historical building material Properties of the Trani stone (Apulia, Southern Italy) and preliminary study for self cleaning treatments*, **12<sup>th</sup> International Congress on the Deterioration and Conservation of Stone**, Columbia University, New York, 2012, 9 p.
- [21] B. De Graef, W. De Windt, J. Dick, W. Verstraete, N. De Belie, *Cleaning of concrete fouled by lichens with the aid of Thiobacilli*, **Materials Structures**, **38**, 2005, pp. 875-882.
- [22] S. Santamaría, P. O'Brien, T. Cooper, *Evaluation of cleaning methods for granite based on petrographic examinations*, **Materials Structures**, **29**, 1996, pp. 185-189.
- [23] I. Maxwell, **Stone Cleaning for Better Or worse? An overview**, Stone cleaning and the nature, soiling and decay mechanisms of stone, Donhead, Great Britain, 1992, p. 32
- [24] M. Young, D. Urquhart, *Abrasive cleaning of sandstone buildings and monuments: an experimental investigation*, **International Conference of Stone Cleaning and the Nature, Soiling and Decay Mechanisms of Stone**, Edinburgh, Scotland, London, 1992, p. 128.
- [25] M. Cooper, *Characterization of laser cleaning of limestone*, **Optics and Laser Technology**, **27**, 1995, pp. 69-73.
- [26] C. Beneking, *Power dissipation in capacitively coupled RF discharge*, **Journal of Applied Physics**, **68**, 1990, pp. 4461-4473.
- [27] A. Godyk, A. Popov, *Power dissipated in low pressure radio-frequency discharge plasma*, **Journal of Applied Physics**, **57**, 1985, pp. 53-58.
- [28] B. Andries, *Electrical characterization of radio frequency parallel-plate capacitively coupled discharges*, **Journal of Vacuum Science and Technology A**, **7**, 1989, pp. 2774-2282.
- [29] J. Butterbaugh, L. Baston, H. Sawin, *Measurement and analysis of radio frequency glow discharge electrical impedance and network power loss*, **Journal of Vacuum Science and Technology A**, **8**, 1990, pp. 916-923.
- [30] G. Franz, **Low Pressure Plasmas and Micro Structuring Technology**, Springer-Verlag, Berlin Heidelberg, New York, 2009, p. 440.
- [31] A. Godyk, R. Piejak, *In situ simultaneous radio frequency discharge power measurements*, **Journal of Vacuum Science and Technology A**, **8**, 1999, pp. 3833-3837.
- [32] L. Sansonnens, A. Howling, Ch. Hollenstein, *A gas flow uniformity study in large-area showerhead reactors for RF plasma deposition*, **Plasma Sources Science and Technology**, **9**, **2**, 2006, pp. 205-209.
- [33] R. Kolasinski, *Fundamental Ion-surface Interactions Plasma Thrusters*, **PhD Thesis**, Pasadena, California, California Institute of Technology, USA, 2007, p. 20.
- [34] J. Reece Roth, **Industrial Plasma Engineering**, Vol. 2, Applications to nonthermal plasma processing, IOP Publishing Ltd, London, 2001, p. 39.
- [35] S. Pignataro, A. Torrisi, O. Puglisis, A. Cavallaro, A. Perniciaro, G. Ferla, *Influence of surface chemical composition on the reliability of Al/Cu bond in electronic devices*, **Applied Surface Science**, **25**, 1986, pp. 127-136.
- [36] R. Cuthrell, F. Gerstle, D. Mattox, *Measurement of residual stress in films of unknown elastic modulus*, **Review of Scientific Instruments**, **60**, 1989, pp. 1018-1020.

- [37] I. Neamtu, A. Ioanid, A. Chiriac, L. Nita, G. Ioanid, M. Popescu, *Polymer coated ferrite nanocomposites synthesized by plasma polymerization*, **Romanian Journal Physics**, **50**, 2005, pp. 1081-1087.
- [38] D. Shia, P. Hea, J. Liana, L. Wanga, W. van Ooija, *Plasma deposition and characterization of acrylic acid thin film on ZnO nano particles*, **Journaql of Materials Research**, **17**, 2002, pp. 2555-2560.
- [39] V. Lisovskiy, J. Booth, K. Landry, D. Douai, V. Cassagne, V. Yegorenkov, *Applying RF current harmonics for end-point detection during etching multi-layered substrates and cleaning discharge chambers with NF3 discharge*, **Vacuum**, **82**, 2008, pp. 321-327.
- [40] M. Konuma, **Film Deposition by Plasma Techniques**, (First edition), Springer-verlag, Berlin Heidelberg, New York, 1992, p. 34.
- [41] M. Libermen, A. Lichtenberg, **Principle of Plasma Discharge and Materials Processing**, (2<sup>nd</sup> edition), John Wiley, Sons, USA, 2005, p. 579.
- [42] Z. Rašková, F. Kr ma, *Plasma chemical reduction for the conservation of archaeological artifacts*, **Publication of Astronomical Observatory Belgrade**, **82**, 2007, pp. 159-170.
- [43] H. Gräfen, E. Horn, H. Schlecker, H. Schindler, M. Spiegel, *Corrosion, 2. High-Temperature*, **Ullmann's Encyclopedia of Industrial Chemistry**, Wiley-VCH Verlag GmbH, Co., 2011, p. 1.
- [44] A. Stoch, J. Stoch, J. Gurbiel, M. Cichoci ska, M. Mikołajczyk, M. Timler, *FTIR study of copper patinas in the urban atmosphere*, **Journal of Molecular Structure**, **596**, 2001, pp. 201-206.
- [45] M. Cooper, D. Emmony, J. Larson, *The evaluation of laser cleaning of stone sculpture*, **Structural Repair and Maintenance of Historical Buildings**, Vol. III, Computational Mechanics Publications, 1993, p. 259.
- [46] H. Gouveia, *Analytical study of the chemical and physical changes induced by KrF laser cleaning of tempera paints*, **Analytical Chemistry**, **74**, 2002, pp. 4662-4671.
- [47] P. Bracco, G. Lanterna, M. Matteini, K. Nakahara, O. Sartiani, A. De Cruz, M. Wolbarsht, E. Adamkiewicz, M. Colomboni, *Er:YAG laser: an innovative tool for controlled cleaning of old paintings: testing and evaluation'*, **Journal of Cultural Heritage**, **4**, 2003, pp.202-205.
- [48] G. Hedley, *Solubility parameters and varnish removal: a survey*. **The Conservator**, **4**, 1980, pp. 12-18.
- [49] G. Alessandrini, A. Sansonetti, A. Pasetti, *The cleaning of stone surfaces: comparison between laser and traditional methods: Evaluation of the harmfulness*, **4<sup>th</sup> International Symposium on the Conservation of Monument in the Mediterranean Basin**, Vol. 3, Technical Chamber of Greece, Athens, 1997, p. 19.
- [50] L. Appolonia, A. Bertone, A. Brunneto, D. Vaudan, *The St. Orso Priori the comparison and testing of cleaning methods*, **Journal of Cultural Heritage**, **1**, 2000, pp. 105-110.
- [51] J. Asmus, M. Seracini, M. Zetler, *Surface morphology of laser cleaned stone*, **Lithoclastia**, **1**, 1976, pp. 23-46.
- [52] A. Koss, J. Marczak, *Evaluation of laser cleaning progress and quality*, **Journal of Heritage Conservation**, **32**, 2012, pp. 109-114.
- [53] R. Balasubramaniam, A. Kumar, *Characterization of Delhi iron pillar rust by X-ray diffraction, Fourier transform infrared spectroscopy and Mössbauer spectroscopy*, **Corrosion Science**, **42**, 2000, pp. 2085-2101.
- [54] B. Petter Jelle, T. Nilsen, *Comparison of accelerated climate ageing methods of polymer building materials by attenuated total reflectance Fourier transform infrared radiation spectroscopy*, **Construction and Building Materials**, **25**, 2011, pp. 2122-2132.
- [55] N. Verhulst, L. Barnden, *The ince Blundell composite marble statue of man with an ivy wreath – 'Marcus Aurelius': Revisited/Restored*, **12<sup>th</sup> International Congress on the Deterioration and Conservation of Stone**, Columbia University, New York, 2012, 15 p.

- [56] S. Tilak, **Biodeterioration of Paintings at Ajanta**, Biodeterioration of Cultural Property. Macmillan, New Delhi, 1991, p. 307.
- [57] M. Yassin, S. Almouqatea, *Assessment of airborne bacteria and fungi in an indoor and outdoor environment*, **International Journal of Environment and Scientific Technology**, **7**, 2010, pp. 535-544.
- [58] S. Thirumala, M. Pradeep, *Study of Fungal Spores Diversity, in Malebenur Region of Karnataka*, **International Journal of Current Microbiology and Applied Sciences**, **2**, 2013, pp. 44-48.
- [59] E. Pye, **Caring for the Past: Issues in Conservation for Archaeology and Museums**, James & James, London, 2001, p. 28.
- [60] S. Joyce Hill, *Changing approaches in art conservation: 1925 to the present, Scientific Examination of Art*, **Conservation and Analysis**, National Academies Press, 2005, p. 41.
- [61] S. Muñoz-Viñas, **Contemporary Theory of Conservation** (First edition), Butterworth Heinemann, London, 2005, p. 192.
- [62] M. El-Gohary, *Degradation of limestone buildings in Jordan: working effects and conservation problems. A critical study according to international codes of practice*, **Adumatu Journal**, **16**, 2007, pp. 7-24.
- [63] S. Hanna, **Conservation of Cultural Heritage: Key Principles and Approaches**, (1<sup>st</sup> edition), Routledge, London. 2013, p. 3.
- [64] J. Patscheider, S. Veprek, *Application of low-pressure hydrogen plasma to the conservation of ancient iron artifacts*, **Studies in Conservation**, **31**, 1986, pp. 29-37.
- [65] M. De Graaf, R. Severens, M. Van de Sanden, R. Meyer, H. Kars, M. Van de Sanden, D. Schram, *Hydrogen atom cleaning of archeological artefacts*, **Journal of Nuclear Materials**, **200**, 1993, pp. 380-382.
- [66] K. Schmidt-Ott, V. Boissonnas, *Low-pressure hydrogen plasma: An assessment of its application on archaeological iron*, **Studies in Conservation**, **47**, 2002, pp. 81-87.
- [67] S. Grassini, E. Angelini, R. d'Agostino, F. Palumbo, G. Ingo, *Advanced plasma treatment for cleaning and protecting precious metal artifacts*, **International Conference on Strategies for Saving Indoor Metallic Collections**, Cairo, Egypt, 2007, p. 127.
- [68] M. El Shaer, A. Soliman, A. Massoud, M. Mobasher, M. Wuttmann, *Computerized Langmuir probe measurements in a capacitively coupled RF discharge*, **28<sup>th</sup> ICPiG**, Prague, Czech Republic, 2007, p. 1610.
- [69] G. Canal, H. Luna, L. Ruchko, R. Galvão, *Design and characterization of an RF plasma cleaner*, **Brazilian Journal of Physics**, **40**, 2010, pp. 108-114.
- [70] K. Schmidt-Ott, *Plasma-reduction: Its potential for use in the conservation of metals*, **Proceedings of Metal 2004**, Canberra ACT 4, 2004, p. 235.
- [71] M. Drews, P. de Vivies, N. Gonzalez, P. Mardikian, *A study of the analysis and removal of chloride in iron samples from the "Hunley"*, **Proceedings of Metal 2004**, Canberra ACT 4, 2004, p. 247
- [72] M. Moreno, M. Labrune, P. Cabarrocas, *Dry fabrication process for heterojunction solar cells through in-situ plasma cleaning and passivation*, **Solar Energy Materials and Solar Cells**, **94**, 2010, pp. 402- 405.
- [73] G. Levitin, K. Reinhardt, D. Hess, *Plasma cleaning for electronic, photonic, biological, and archeological applications*, Ch. 2, **Developments in Surface Contamination and Cleaning**, 2013, p. 55.
- [74] M. Derrick, D. Stulik, J. Landry, **Infrared Spectroscopy in Conservation Science**, Getty Publications, USA, 2000, p.13.
- [75] Y. Oh, C. Chung, *Fourier transform infrared spectroscopic observation of the surface reactions during electroless copper deposition in formaldehyde based electrolyte*, **Thin Solid Films**, **515**, 2006, pp. 2137-2144.

- [76] P. Sathya, G. Velraj, S. Meyvel, *Fourier transform infrared spectroscopic study of ancient brick samples from Salavankuppam Region, Tamilnadu, India*, **Advances in Applied Science Research**, **3**, 2012, pp. 776-779.
- [77] D. Bikiaris, S. Daniilia, S. Sotiropoulou, O. Katsimbiri, E. Pavlidou, A. Moutsatsou, Y. Chrysoulakis, *Ochre-differentiation through micro-Raman and micro-FTIR spectroscopies: application on wall paintings at Meteora and Mount Athos, Greece*, **Spectrochimica Acta Part A: Molecular and Biomolecular Spectroscopy**, **56**, 2000, pp. 3-18.
- [78] M. El-Gohary, *Investigation on limestone weathering of El-Tuba Minaret El-Mahalla, Egypt: A case study*, **Mediterranean Archaeology and Archaeometry**, **10**, 2010, pp. 61-79.
- [79] R. Ravisankar, S. Kiruba, P. Eswaran, G. Senthilkumar, A. Chandrasekaran, *Mineralogical characterization studies of ancient potteries of Tamilnadu, India by FT-IR Spectroscopic Technique*, **E-Journal of Chemistry**, **7**, 2010, pp. S185-S190.
- [80] S. Gustafsson, **Corrosion Properties of Aluminum Alloys and Surface Treated Alloys in Tap Water**, Sapa Technology, 2011, p. 6.
- [81] S. Alexandrova, A. Szekeres, *RF plasma cleaning of the oxide surface as a possibility for contamination control in MOS structures*, **Vacuum**, **51**, 1998, pp. 469-472.
- [82] T. Misawa, K. Asami, K. Hashimoto, S. Shimodaira, *The mechanism of atmospheric rusting and the protective amorphous rust on low alloy steel*, **Corrosion Science**, **14**, 1974, pp. 279-289.
- [83] V. Chawla, P. Gurbuxani, G. Bhagure, *Corrosion of water pipes: A comprehensive study of deposits*, **Journal of Minerals, Materials Characterization. Engineering**, **11**, 2012, pp. 479-492.
- [84] S. Dhanapandiana, M. Shanthib, C. Manoharana, *FTIR and Mössbauer studies on industrial clay bricks from three different regions of Tamilnadu state*, **International Journal of Current Research**, **4**, 2010, pp. 122-126.
- [85] C. Zaffino, V. Guglielmi, S. Faraone, A. Vinaccia, S. Bruni, *Exploiting external reflection FTIR spectroscopy for the in-situ identification of pigments and binders in illuminated manuscripts. Brochantite and posnjakite as a case study*, **Spectrochimica Acta Part A: Molecular, Biomolecular Spectroscopy**, **136**, 2015, pp. 1076-1085.
- [86] F. Miller, C. Wilkins, *Infrared spectra and characteristic frequencies of inorganic ions*, **Analytical Chemistry**, **24**, 1952, pp. 1253-1294.
- [87] M. Ursescu, T. Malutan, S. Ciovica, *Iron gall inks influence on papers' thermal degradation: FTIR spectroscopy applications*, **European Journal of Science and Theology**, **5**, 2009, pp. 71-84.
- [88] F. Cappitell, L. Toniolo, A. Sansonetti, D. Gulotta, G. Ranalli, E. Zanardini, C. Sorlini, *Advantages of Using Microbial Technology over Traditional Chemical Technology in Removal of Black Crusts from Stone Surfaces of Historical Monuments*, **Applied and Environmental Microbiology**, **73**, 2007, pp. 5671-5675.
- [89] C. Hwang, T. Huynh, *Evaluation of the performance and microstructure of ecofriendly construction bricks made with fly ash and residual rice husk ash*, **Advances in Materials Science and Engineering**, **2015**, 2015, pp. 1-11.

---

Received: March, 02, 2016

Accepted: August, 25, 2016